

300 SERIES 3/2 WOODRAKE GRAPPLE

Open	86"	2184 mm
Area tip to tip	6.6 ft ²	0.61 m ²
Cylinder Bore	4"	102 mm
Lock valve on Cylinder	Included	
Cylinder Max. Pressure	5000 psi	345 bar
Weight (grapple only)	3150 lb	1429 kg

300S SERIES MANIPULATING ROTATOR

Rotation	Unlimited	
Lifting capacity	200,000 lb	90718 kg
Max pressure	3000 psi	207 bar
Max torque	127851 lb-in	14445.2 Nm
Rotator flow	22 gpm	83 L/min
Rotation speed	14 rpm	
Weight	1500 lb	680 kg

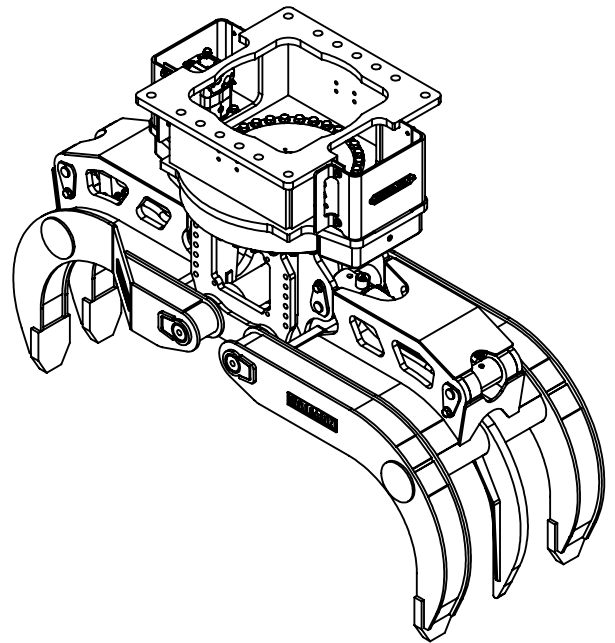

555S GRAPPLE SAW OPTION

Motor size	0.61/1.16 in ³	10/19 cc
Required pressure	3500 psi	241 bar
Required flow	30/42 gpm	114/159 Lpm
Saw bar length	35/39 in	889/991 mm
Weight	375 lb	170 kg

650S GRAPPLE SAW OPTION

Motor size	2.44 in ³	40 cc
Required pressure	3100 psi	214 bar
Required flow	55 gpm	208 Lpm
Saw bar length	39/45 in	991/1143 mm
Weight	584 lb	265 kg

BATEMAN MANUFACTURING
5 WINSTAR ROAD
ORO-MEDONTE, ONTARIO
L0L 2L0, CANADA

WWW.BATEMANMANUFACTURING.COM
MAIL@BATEMANMANUFACTURING.COM
PHONE: (705) 487-5020
FAX: (705) 487-5290

