



TECHNICAL SPECIFICATIONS

MODEL: BMG16-100-M36

160S, 1 YD³, 36" MAGNET GRAPPLE, BN24162

1 YD³ 160 SERIES MAGNET GRAPPLE

Open	106"	2694.0mm
Capacity	1.00 yd ³	0.75 m ³
Cylinder Bore	3"	76mm
Cylinder Max. Pressure	5000 psi	345 bar
Rotator Max. Pressure	2540 psi	175 bar
Flow (Rotate Circuit)	10 gpm	38 Lpm
Grapple Rotation, At 10 gpm	29 rpm	
Flow (Open/Close Circuit)	50 gpm	189 Lpm
Cycle Time Theoretical (Open/Close Circuit)	1.5 sec/2 sec	
Weight (with rotator)	5020 lb	2277 kg
Magnet	36" ∅, 230 VDC, 5.98 kw	

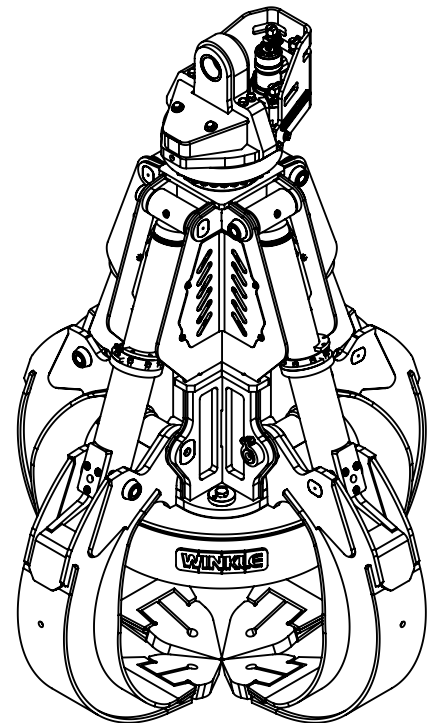
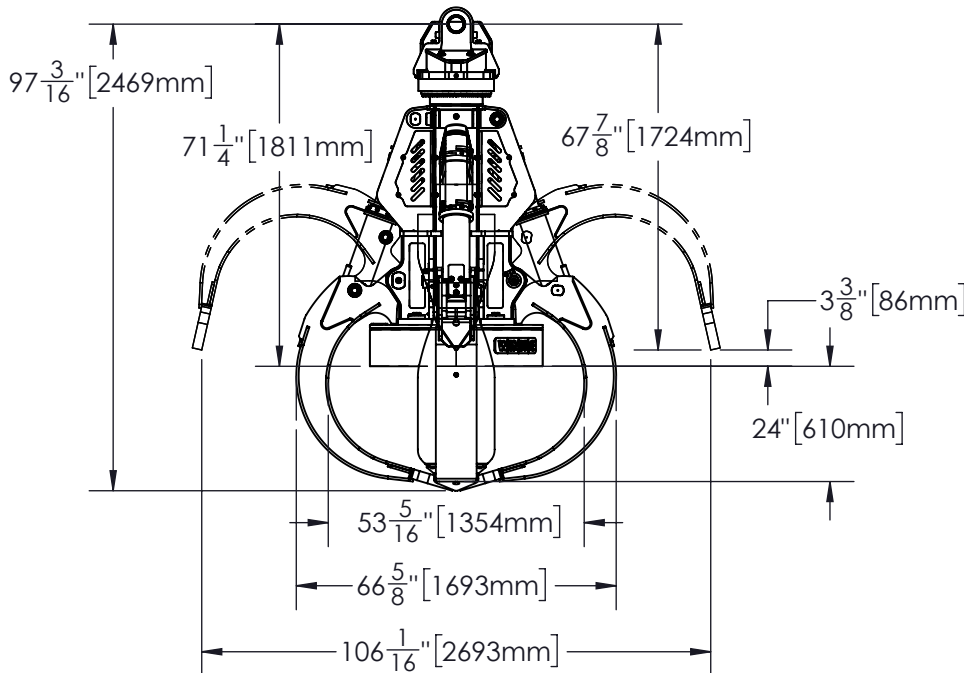
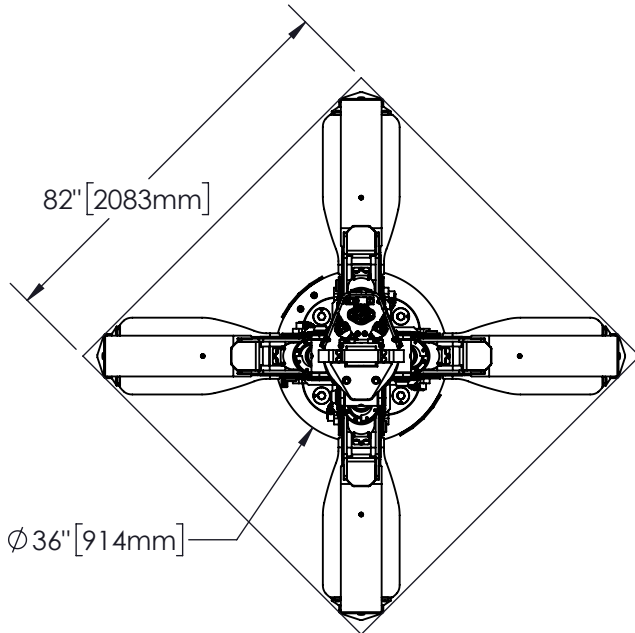

5 Winstar Road
Oro-Medonte, ON L0L 2L0, Canada

info@batemanmanufacturing.com
batemanmanufacturing.com

705-487-5020

