



TECHNICAL SPECIFICATIONS

MODEL: BMG16-100-M30

160S, 1 YD<sup>3</sup>, 30" MAGNET GRAPPLE, BN24398

1 YD<sup>3</sup> 160 SERIES MAGNET GRAPPLE

Open	106 "	2694.0mm
Capacity	1.00 yd <sup>3</sup>	0.75 m <sup>3</sup>
Cylinder Bore	3 "	76mm
Cylinder Max. Pressure	5000 psi	345 bar
Rotator Max. Pressure	2540 psi	175 bar
Flow (Rotate Circuit)	10 gpm	38 Lpm
Grapple Rotation, At 10 gpm	29 rpm	
Flow (Open/Close Circuit)	50 gpm	189 Lpm
Cycle Time Theoretical (Open/Close Circuit)	1.5 sec/2 sec	
Weight (with rotator)	4820 lb	2186 kg
Magnet	30" $\varnothing$ , 230 VDC, 4.94 kw	

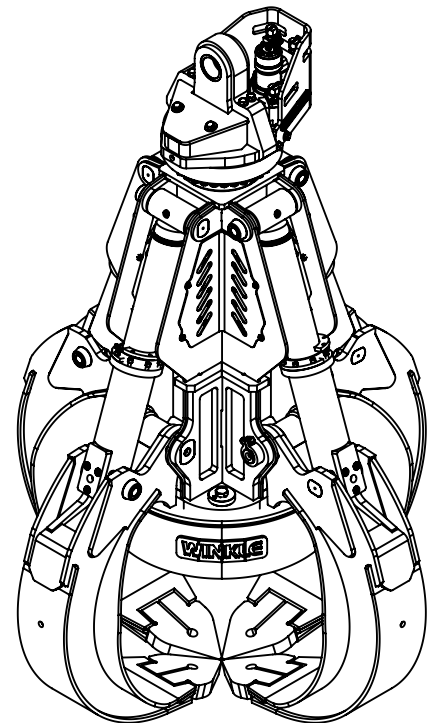
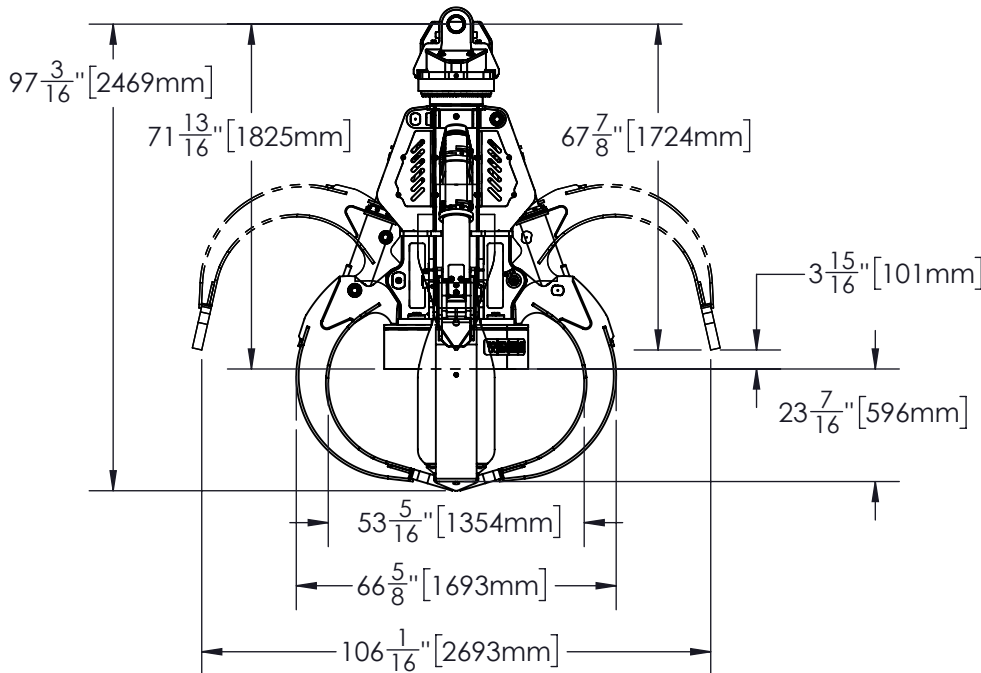
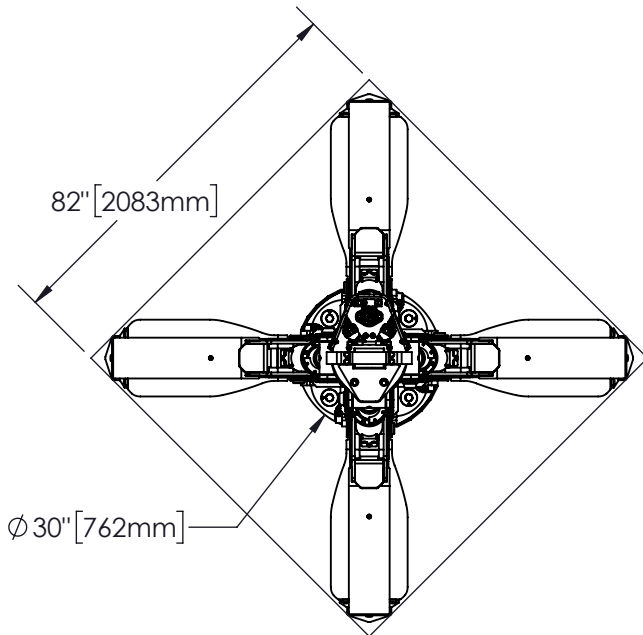

5 Winstar Road  
Oro-Medonte, ON L0L 2L0, Canada

info@batemanmanufacturing.com  
batemanmanufacturing.com

705-487-5020

