

1 YD GRAPPLE

Open	95.00 "	2413.0mm
Capacity	1 yd ³	0.76 m ³
Cylinder bore	3"	76mm
Lock valve on cylinders	Excluded	
Cylinder max. pressure	5000 psi	345 bar
Weight (with rotation)	3700 lb	1678 kg

150/160 SERIES DANGLING ROTATOR

Rotation	Unlimited	
Lifting capacity	74200 lb	33657 kg
Max pressure	1450 psi	10.0 MPa
Torque at max. pressure	18400 lb-in	24947.1 Nm
Rotator flow	10 gpm	38 L/min
Rotation speed	15 rpm	
Weight	530 lb	240 kg

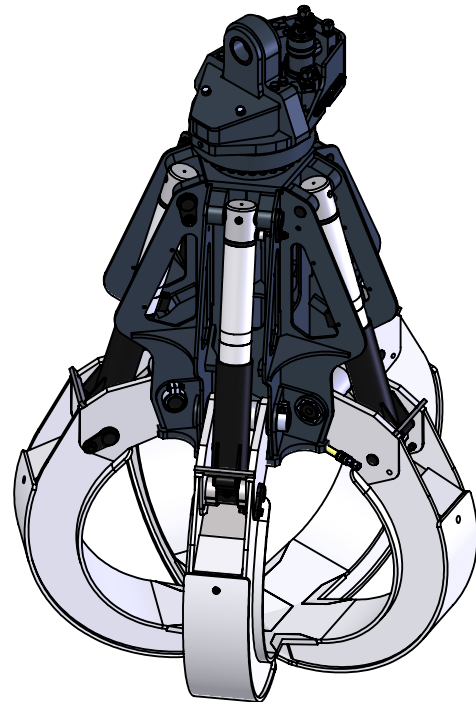
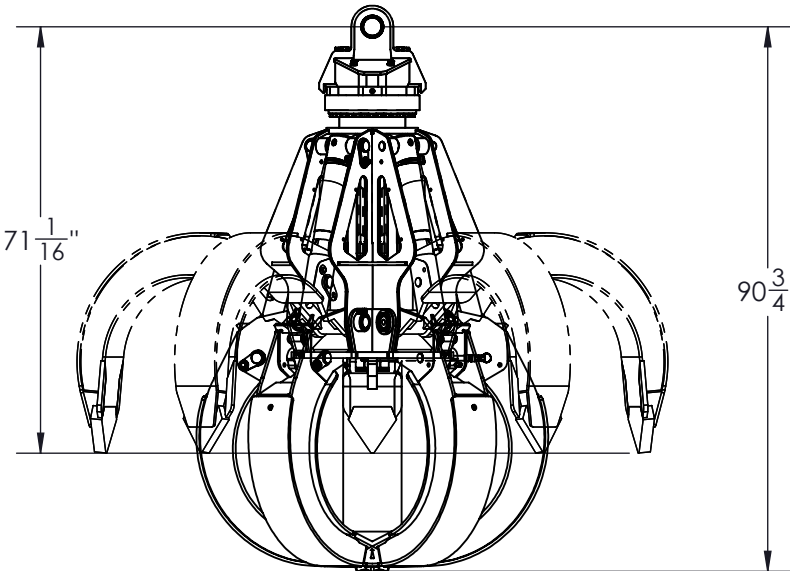

BATEMAN MANUFACTURING
 5 WINSTAR ROAD
 ORO-MEDONTE, ONTARIO
 L0L 2L0, CANADA

WWW.BATEMANMANUFACTURING.COM
 MAIL@BATEMANMANUFACTURING.COM
 PHONE: (705) 487-5020
 FAX: (705) 487-5290

